

## Free flow , Non Shrink , High strength Cementitious grout for high gap thicknesses

### Uses

Conbextra TS is used for precision grouting of machine Foundations , column stanchions , Precast elements with high gap widths ranging from 75 mm to 500 mm. The product can also be used for filling box sections.

### Advantages

- Gaseous expansion system compensates for shrinkage in plastic state
- No metallic iron content to cause staining
- Pre-packed material overcomes onsite batching variations
- High early & Ultimate strength without use of chlorides
- Excellent flow characteristics
- Suitability for grouting gap thicknesses up to 500 mm

### Description

Conbextra TS is supplied as a ready to use dry powder . The Addition of controlled amount of clean water produces a free flowing , Non Shrink grout suitable for grouting gap thickness ranging from 75mm – 500 mm . The low Water/ Powder ratio ensures high early strength and long term durability.

Conbextra TS is a blend of Portland cements, graded Fillers Selected aggregates and chemical additives which impart controlled expansion in the plastic state while minimising the water demand .The size & gradation of filler is designed in a way to have no segregation or bleeding and also reduces the exothermic heat generation thereby risk of thermal cracking common with gap thicknesses in excess of 100 mm.

### Technical support

An experienced technical advisory team is available to give technical service on request.

### Properties

Compressive strength : (IS 4031 Part 6)

| Age (days) | Compressive strength (N/mm <sup>2</sup> ) |
|------------|-------------------------------------------|
|            | Consistency                               |
|            | Flowable (W/P 0.14)                       |
| 1          | 20.0                                      |
| 3          | 35.0                                      |
| 7          | 48.0                                      |
| 28         | 65.0                                      |

Flexural strength ( BS 4551, 1998)

| Age (days) | Flexural strength (N/mm <sup>2</sup> )<br>W/P 0.14 |
|------------|----------------------------------------------------|
| 28         | 6.70                                               |

Tensile strength

| Age (days) | Flexural strength (N/mm <sup>2</sup> )<br>W/P 0.14 |
|------------|----------------------------------------------------|
| 7          | 5.49                                               |
| 28         | 9.44                                               |

Expansion (%)

|                                    |                                                                     |
|------------------------------------|---------------------------------------------------------------------|
|                                    | 1.00                                                                |
| Pullout bond strength (W/P - 0.14) | 15.0 N/mm <sup>2</sup> @ 7 days<br>25.0 N/mm <sup>2</sup> @ 28 days |

Time for expansion (after mixing )

|                   |                                                                             |
|-------------------|-----------------------------------------------------------------------------|
|                   | Start : 20 minutes<br>Finish : 120 minutes                                  |
| Fresh wet density | Approximately 2043kg/m <sup>3</sup><br>depending on actual consistency used |

Coefficient of thermal expansion  $11 \times 10^{-6}/^{\circ}\text{C}$

Unrestrained expansion

Upto 2 % in the plastic state enables to overcome shrinkage.

Pressure to restrain

0.004 N/mm<sup>2</sup> approx.

# Conbextra TS

## Specification Clauses

### Performance specification

All grouting with gap thickness ranging from 75 – 500 mm shall be carried out using conbextra TS - A pre bagged single component cementitious material Which complies with requirements of ASTM C 1107 Type A.

The pre weighed material shall be mixed with clean water to The required consistency . The quantity of water shall not exceed the defined W/P ratio of 0.14.

The compressive strength of grout shall exceed 40 Mpa @ 7 Days & 60 Mpa at 28 Days . The grout shall expand and the increase in Volume shall not be lower than 1 %.

The storage, Handling and placement of the grout must be In strict accordance with the manufacturer's instructions.

### Typical detail of stanchion base plate

The compressive strength of the grout must exceed 40 N/mm<sup>2</sup> at 7 days and 60 N/mm<sup>2</sup> at 28 days.

The flexural strength of grout must exceed 9N/mm<sup>2</sup> @ 28 days. The fresh wet density of the mixed grout must exceed 2000 kg/m<sup>3</sup>.

The storage, handling and placement of the grout must be in strict accordance with the manufacturer's instructions.

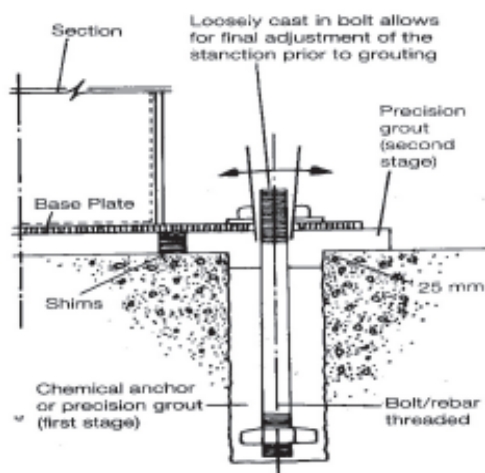

## Application instructions

### Preparation

#### Foundation surface

The substrate surface must be free from oil, grease or any loosely adherent material. If the concrete surface is defective or has laitence, it must be cut back to a sound base. Bolt holes and fixing pockets must be blown clean of any dirt or debris.

#### Pre-soaking

Several hours prior to placing, the concrete substrates should be saturated with fresh water.

Immediately before grouting takes place any free water should be removed with particular care being taken to blow out all bolt holes and pockets.

#### Base plate

It is essential that this is clean and free from oil, grease or scale. Air pressure relief holes should be provided to allow venting of any isolated high spots.

#### Levelling shims

If these are to be removed after the grout has hardened, they should be treated with a thin layer of grease.

#### Formwork

The formwork should be constructed to be leakproof. This can be achieved by using foam rubber strip or mastic sealant beneath the constructed formwork and between joints.

In some cases it is practical to use a sacrificial semi-dry sand and cement formwork. The formwork should include outlets for pre-soaking.

#### Unrestrained surface area

This must be kept to a minimum. Generally the gap width between the perimeter formwork and the plate edge should not exceed 150mm on the pouring side and 50mm on the opposite side. It is advisable, where practical, to have no gap at the flank sides.

# Conbextra TS

## Mixing and placing

### Mixing

For best results a mechanically powered grout mixer should be used. When quantities up to 50kg are used, a heavy duty slow speed drill (400-500 rpm) fitted with a paddle is suitable.. Larger quantities will require a heavy duty mixer.

To enable the grouting operation to be carried out continuously, it is essential that sufficient mixing capacity and labour are available. The use of a grout holding tank with provision to gently agitate the grout may be required.

### Consistency of grout mix

The quantity of clean water required to be added to a 25kg bag to achieve the desired consistency is given below :

Flowable : 5.5 litres

The selected water content should be accurately measured into the mixer. The total content of the Conbextra TS bag should be slowly added and continuous mixing should take place for 5 minutes. This will ensure that the grout has a smooth even consistency.

### Placing

At 30°C place the grout within 20 minutes of mixing to gain full benefit of the expansion process.

Conbextra TS can be placed in thicknesses up to 500mm in a single pour when used as an underplate grout.

Any bolt pockets must be grouted prior to grouting between the substrate and the base plate.

Continuous grout flow is essential. Sufficient grout must be prepared before starting. The time taken to pour a batch must be regulated to the time to prepare the next one.

## Typical hopper system

**Removable hopper :** For large pours the grout may be hand placed or pumped into a removable hopper ( trough)

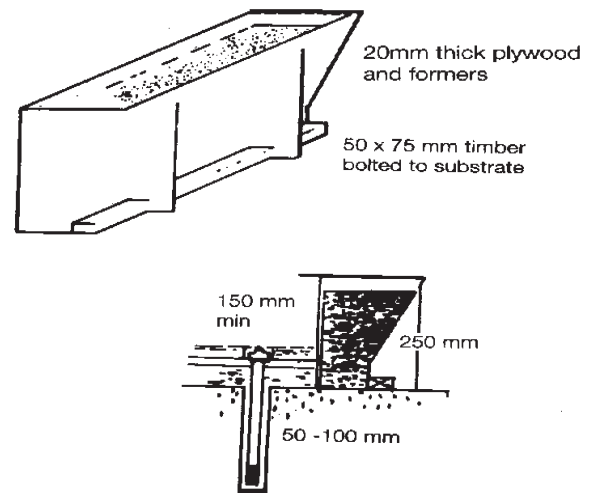

Pouring should be from one side of the void to eliminate any air or presoaked water becoming trapped under the base plate. It is advisable to pour the grout across the shortest distance of travel. The grout head must be maintained at all times so that a continuous grout front is achieved.

Where large volumes have to be placed Conbextra TS may be pumped. A heavy duty diaphragm pump is recommended for this purpose. Screw feed and piston pumps may also be suitable.

### Curing

On completion of the grouting operation, exposed areas should be thoroughly cured. This should be done by the use of Concure WB curing membrane, continuous application of water and/or wet hessian.

### Limitations

#### Low temperature working

When the air or contact surface temperatures are 10°C or below on a falling thermometer, warm water ( 30 - 40°C) is recommended to accelerate strength development.

For ambient temperature below 10°C the formwork should be kept in place for at least 36 hours.

Normal precautions for winter working with cementitious materials should then be adopted.

# Conbextra TS

---

## High temperature working

At ambient temperatures above 40° C, cool water ( below 20°C) should be used for mixing the grout prior to placement.

## Estimating Packaging

Conbextra TS is supplied in 25 kg moisture resistant bags.

## Yield

Allowance should be made for wastage when estimating quantities required. The approximate yield per 25 kg bag for different consistency is :

| Consistency     | Flowable |
|-----------------|----------|
| Yield ( litres) | 12.0     |

## Storage Shelf life

Conbextra TS has a shelf life of 6 months if kept in a dry store in sealed bags. If stored in high temperature and high humidity locations, the shelf life may be reduced.

## Precautions

### Health and Safety instructions

Conbextra TS is alkaline and should not come into contact with skin and eyes. Inhalation of dust during mixing should be avoided.

Gloves, goggles and dust mask should be worn.

If contact with skin occurs, it shall be washed with water. Splashes to eyes should be washed immediately with plenty of clean water and medical advice sought.

### Fire

Conbextra TS is non flammable.

### Additional information

For further details about the use and selection of grouts refer to the Fosroc Information module entitled 'Precision grouting in the Construction industry'.

## Important note :

Fosroc products are guaranteed against defective materials and manufacture and are sold subject to its standard terms and conditions of sale, copies of which may be obtained on request. Whilst Fosroc endeavours to ensure that any advice, recommendation specification or information it may give is accurate and correct, it cannot, because it has no direct or continuous control over where or how its products are applied, accept any liability either directly or indirectly arising from the use of its products whether or not in accordance with any advice, specification, recommendation or information given by it.



## Berger Fosroc Limited

Corporate Address:

'Berger House', House # 08, Road # 02, Sector # 03, Uttara Model Town, Dhaka 1230, Bangladesh.

telephone( Hunting) : +880248953665, fax : +880248951350,

e-mail : enquiry.bangladesh@bergerfosroc.com, website : www.bergerfosroc.com

